



## GENUINE PARTS

### INSTALLATION INSTRUCTIONS

<b>DESCRIPTION:</b>	Nose Mask																						
<b>APPLICATION:</b>	Sentra SL & SR																						
<b>PART NUMBER:</b>	Nose Mask (999N1 LZ000/LZ0DS & 999N1 LZ001/LZ1DS)																						
<b>KIT CONTENTS:</b>																							
<table border="1"><thead><tr><th>Item</th><th>QTY</th><th>Part Description</th><th>Service Part Number</th></tr></thead><tbody><tr><td>A</td><td>1</td><td>Nose Mask</td><td>N/A</td></tr><tr><td>B</td><td>2</td><td>Squarehead Retainers</td><td>N/A</td></tr><tr><td>C</td><td>2</td><td>Snap Screws</td><td>N/A</td></tr><tr><td>D</td><td>1</td><td>Installation Instructions Replacement Template</td><td>999V2 AW000</td></tr></tbody></table>	Item	QTY	Part Description	Service Part Number	A	1	Nose Mask	N/A	B	2	Squarehead Retainers	N/A	C	2	Snap Screws	N/A	D	1	Installation Instructions Replacement Template	999V2 AW000			
Item	QTY	Part Description	Service Part Number																				
A	1	Nose Mask	N/A																				
B	2	Squarehead Retainers	N/A																				
C	2	Snap Screws	N/A																				
D	1	Installation Instructions Replacement Template	999V2 AW000																				
<b>TOOLS REQUIRED:</b>																							
<ul style="list-style-type: none"><li>• Scissors</li><li>• Phillips Screwdriver</li><li>• Flathead Screwdriver</li></ul>																							
<b>PRE-INSTALLATION CAUTIONS/NOTES:</b>																							
<ul style="list-style-type: none"><li>• The area to be covered by the mask must be free of dirt. The flannel surface of the nose mask must be especially clean.</li><li>• Both the vehicle and the mask must be completely dry. If moisture is present under the mask and is allowed to dry, it may cause the paint to cloud. If mask gets wet, remove and allow to dry completely.</li><li>• Any repainted surface in contact with mask must be completely cured.</li><li>• DO NOT pull the mask from any of the openings when installing the mask. This may result in DAMAGE to your mask.</li><li>• If the nose mask should flap due to high speed or wind conditions, stop car and adjust or remove mask.</li></ul>																							
<b>CARE OF NOSE MASK:</b>																							
<ul style="list-style-type: none"><li>• To clean the vinyl and flannel backing, use a cleaner such as "409" or "Fantastic".</li><li>• The vinyl surface may be cleaned by simply spraying the cleaner onto the vinyl and wiping off with a cloth or sponge.</li><li>• To clean the flannel backing, liberally spray the cleaner on the area to be cleaned. If heavily soiled, use a cloth or sponge with the cleaner and rub the soiled area gently. Repeat if necessary. Rinse completely with clear water when finished. Hang to dry, but not in direct sunlight. Before installation, ensure both the vehicle and the nose mask are completely dry. If there is moisture under the nose mask and it is not allowed to dry, paint clouding can occur.</li></ul>																							
<b>⚠ CAUTION</b>																							
Caution attach all elastics with hooks and clips carefully and securely. Accidental release may cause injury.																							

## INSTALLATION PROCEDURE:

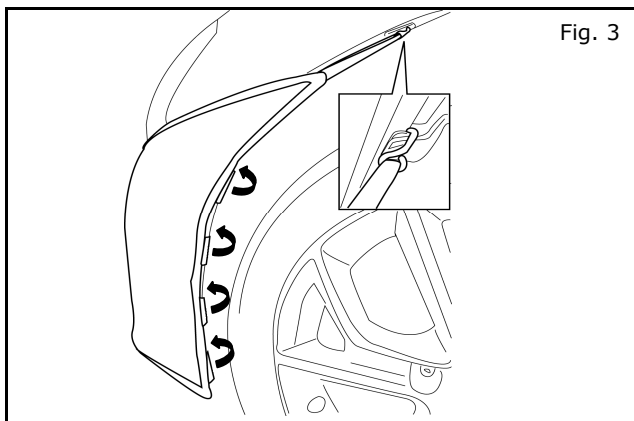
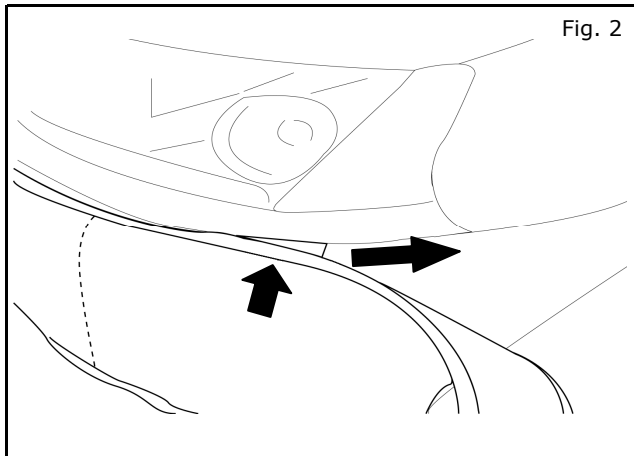
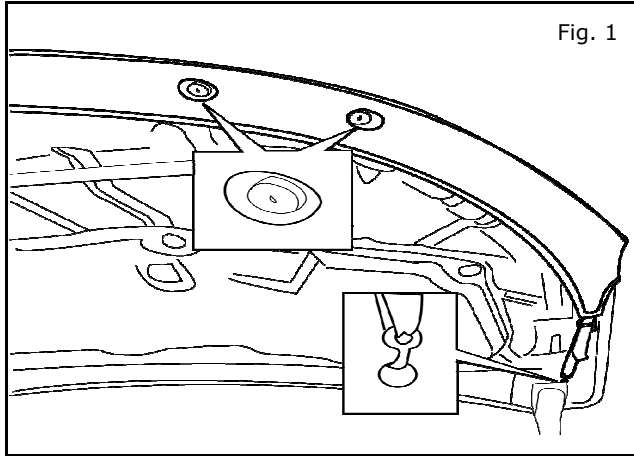

- 1) Open hood and place mask over hood edge.
- 2) Attach hook to hole on underside of hood, gently tighten strap to keep hook in hole and repeat on other side.
- 3) Tighten straps to align holes with rubber stoppers.

### NOTE:

**Pull down on edge of mask so seam is completely under hood.**

- 4) Remove license plate and license plate bracket (if applicable).
  - a) Remove 2 license plate screws.
  - b) Remove 2 license plate bracket screws.
- 5) Insert outer pad under headlamp and slide rearward.

- 6) Attach hook above and behind clip.
- 7) Repeat steps 5 and 6 on other side.
- 8) Pull mask down.
- 9) Attach 4 clips to inside edge of fascia.
- 10) Repeat steps 8 and 9 on other side.

**INSTALLATION PROCEDURE:** (continue)

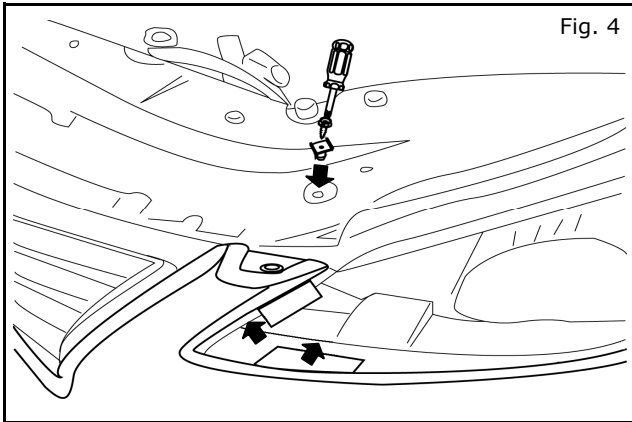

- 11) Using a flathead screwdriver remove plastic push pin from upper fascia under the hood.
- 12) Replace push pin with squarehead retainers.
- 13) Screw snap screws into retainers.
- 14) Snap mask onto newly attached hardware.
- 15) Insert pad into the gap under the headlamp.
- 16) Perform steps 11) through 15) on other side.

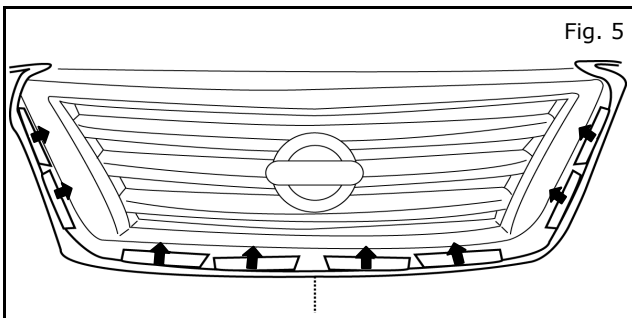

- 17) Gently lift the grille and insert 8 pads into gap between the upper grille and front fascia.

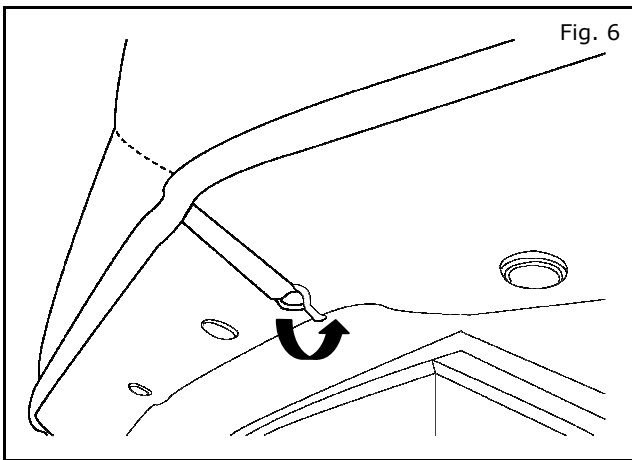

- 18) Attach hook to rear edge of front bumper.
- 19) Perform step 18) on other side.

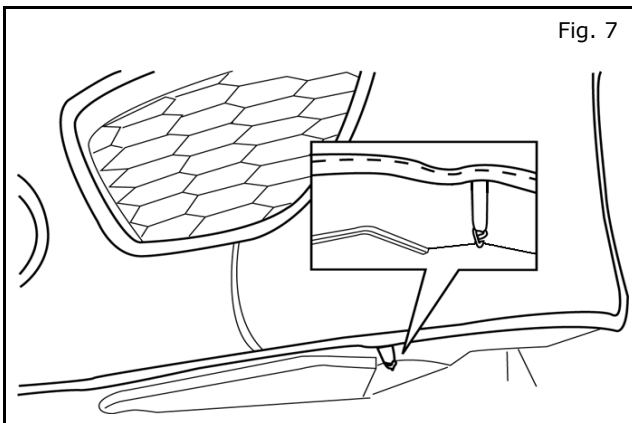

- 20) Attach hook to notch on inside edge of front bumper.
- 21) Perform step 20) on other side.

**INSTALLATION PROCEDURE:** (continue)

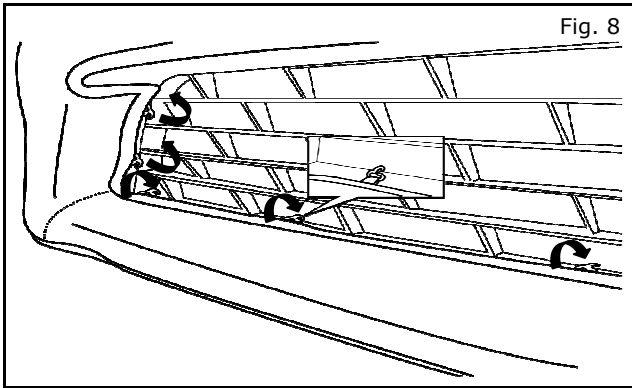

22) Attach 10 hooks to front lower grille.

**NOTE:**  
**If vehicle had a license plate bracket, perform steps 23-25.**

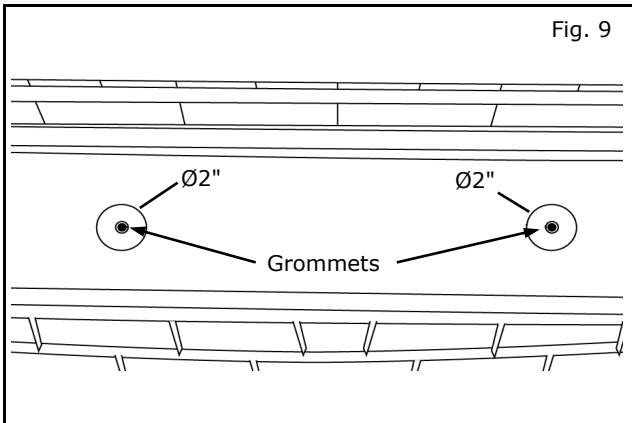

- 23) Poke holes through mask into center license plate brackets grommets.
- 24) Cut clearance holes (1"-2") so that license plate bracket pads will rest on fascia.
- 25) Reinstall license plate bracket and plate.